



STAND MIXER User Guide

Item: 762044

*Recipes
Inside!*



Ginnys.com • 800-544-1590

 Facebook.com/GinnysBrand

 Pinterest.com/GinnysBrand

Thank you for purchasing this new Ginny's Brand Stand Mixer. This mixer is not only easy on the eye, it is easy to use and powerful enough to handle any job in your kitchen! The rotating mixer head works with a beater, whisk or dough hook— so whether you are whipping cream or kneading bread dough—you have the tool you need. Enjoy!

TABLE OF CONTENTS

Important Safeguards	3
Electrical Safety and Specifications	4
Get to Know Your Mixer	5
How to Operate	6–7
Troubleshooting	8
Cleaning & Care	9
Recipes	10–15
Warranty	16

IMPORTANT SAFEGUARDS

READ CAREFULLY BEFORE USING AND SAVE THESE INSTRUCTIONS!

- FOR HOUSEHOLD USE ONLY. DO NOT use this appliance for other than its intended use.
- REMOVE all packaging materials and labels before first use. Please dispose of the packaging materials via the appropriate recycling system, in an environmentally friendly manner.
- **WASH all removable parts before first use. See Cleaning & Care.**
- A SHORT CORD is provided to reduce the hazards resulting from entanglement or tripping. DO NOT drape the cord over the counter or tabletop, where it can be pulled on or tripped over. NEVER wrap the cord tightly around the appliance, as this may cause the cord to fray/break.
- We DO NOT recommend using an extension cord with this appliance. However, IF AN EXTENSION CORD IS USED, the marked electrical rating should be at least as great as the electrical rating of this appliance.
- CLOSE SUPERVISION is necessary when using this appliance near CHILDREN. DO NOT insert anything into the rotating hook, whisk or beater while the machine is working.
- A FIRE may occur if this appliance is used near FLAMMABLE MATERIALS, including curtains, towels, walls, etc. DO NOT place any paper, plastic, or other non-food items in the appliance. DO NOT place the appliance or its cord on or near a heated surface, or in a heated oven.
- This appliance should always be used on a STABLE, DRY, HEAT-RESISTANT SURFACE.
- DO NOT use near water. DO NOT use the appliance with wet hands. If the appliance is humid or wet, unplug it immediately.
- DO NOT use an accessory or attachment not recommended by Ginny's, as this may cause injury, or damage the appliance.
- KEEP HANDS, HAIR AND CLOTHING AWAY FROM ALL MOVING PARTS.
- Always use OVEN MITTS when handling hot food.
- DO NOT use outdoors.
- TURN OFF AND UNPLUG this appliance when not in use.
- NO SERVICEABLE PARTS INSIDE THIS APPLIANCE.
- DO NOT USE AN APPLIANCE WITH A DAMAGED CORD OR PLUG, OR AFTER THE APPLIANCE MALFUNCTIONS, OR HAS BEEN DAMAGED IN ANY MANNER.
- Appliances contain valuable materials that can be recycled. Please dispose of your old appliances using appropriate collection systems.

ELECTRICAL SAFETY

This appliance is equipped with a polarized plug in which one prong is wider than the other. This is a safety feature to reduce the risk of electrical shock. The plug will fit into a polarized outlet only one way. If you are unable to insert the plug into the outlet, try reversing the plug. If it still does not fit, contact a qualified electrician. Do not attempt to modify the plug in any way. Ginny's cannot accept any liability for damage or injury resulting from failure to observe these safety procedures.

SPECIFICATIONS

POWER RATING	120V, 60Hz, 600W
CAPACITY	5.5-Quart Bowl
CORD LENGTH	40"
DIMENSIONS	14.25" L x 7" W x 12.5" H
MODEL	SM-1519X

GET TO KNOW YOUR MIXER

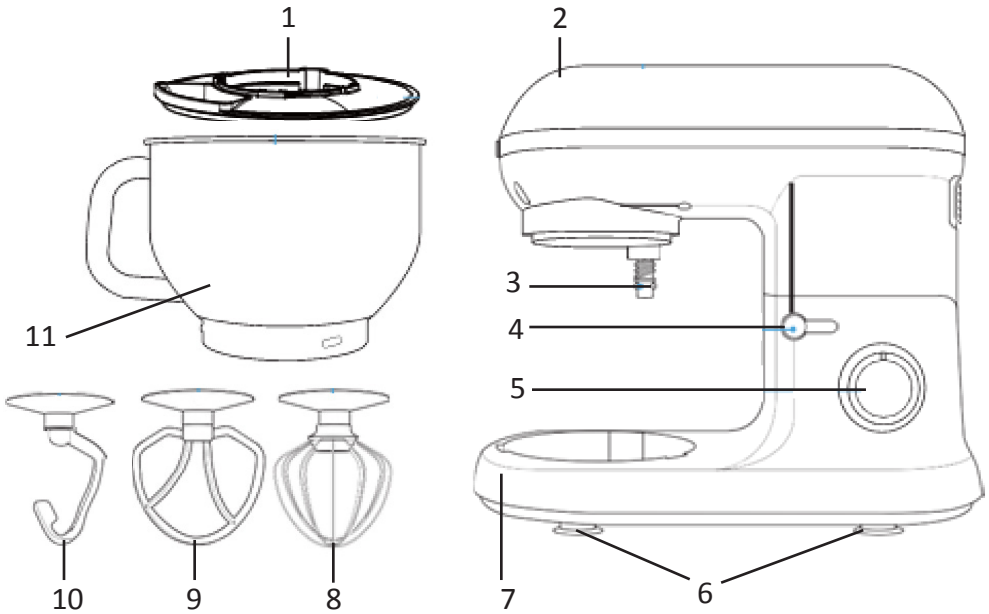

1. Removable Splash Guard
2. Mixer Head
3. Attachment Shaft
4. Head Release Lever
5. Speed Dial
6. Suction Foot (4)
7. Mixer Base
8. Whisk Attachment
9. Beater Attachment
10. Dough Hook Attachment
11. Mixing Bowl

HOW TO OPERATE

1. Set the speed dial to OFF.
2. To raise the mixer head, place your left hand on top of the mixer head and push the head release lever down with your right hand; ease the head up until it stops. Release the lever and the mixer head will stay locked in this position.
3. Align the bowl with the grooves on the mixer base. To lock the mixing bowl, turn it clockwise until it stops.
4. If using the splash guard, push it up onto the mixer head. Be sure to position the hole in the splash guard toward you so you can add ingredients easily, if needed.
5. Align the beater, hook or whisk attachment so the grooves on the attachment match to the shaft located under the mixer head. With some pressure, push the attachment towards the mixer head (moving the spring upward) and twist the attachment in a counter-clockwise direction.
6. Add ingredients into the mixing bowl per your recipe. Do not overfill.
7. Place your left hand on top of the mixer head and push the head release lever down with your right hand. Slowly but firmly push the mixer head down until it locks in place. Release the lever.
8. Plug the power cord into an outlet. The speed dial will illuminate and flash blue.

Note: To prevent splattering, always begin mixing at a low speed and progress toward the desired speed.

Mixing Guide

Speed Setting	Purpose	Attachment	Type of Mixture
1-2	Kneading	Dough hook	LOW: dough for pizza, pasta, bread, etc.
1-2	Folding	Beater	LOW: heavy batter
3-4	Light Mixing	Beater	MEDIUM: cakes, biscuits, icing, etc.
5-6	Aerating & Whisking	Whisk	HIGH: egg whites, cream, etc.
Pulse	Quick bursts of power	Whisk or Beater	HIGH: for small jobs, quick mixing

(continued on page 7)

HOW TO OPERATE

9. To begin mixing, turn the speed dial in a clockwise direction. The speed dial will illuminate blue. Increase the speed per your recipe. Use the mixing guide on page 6 as a reference.
10. Use PULSE (when you require a quick burst of power or for quick incorporations) by turning the speed dial counter-clockwise and hold in this position. **Hold the dial at PULSE for no more than 30 seconds at one time.** When the dial is released, it returns to OFF automatically.
11. Stop the mixer, as needed, and lift the head to scrape the bowl sides with a spatula. Lower the head again before resuming mixing.
12. When mixing is complete, turn the speed dial to OFF and unplug from the outlet.
13. Raise the head, remove the attachment (with some pressure, push the attachment toward the head, and twist the attachment in a clockwise direction; pull the attachment from the shaft).
14. Twist the bowl counter-clockwise to remove it from the base.

Note: With heavy mixtures, do not operate the machine for more than 6 minutes at once, and then allow the mixer to cool down for about 10 minutes.

TROUBLESHOOTING

Problem	Solution
Over-mixing has occurred	<ul style="list-style-type: none">• Mix for the recommended time in the recipe to avoid over-mixing.
Egg whites are not whipping	<ul style="list-style-type: none">• Be sure the whisk attachment and mixing bowl are completely clean and dry before use, as even a small amount of fat will affect the whipping performance.
Bread dough is not combining	<ul style="list-style-type: none">• Some brands of flour absorb more liquid than others, so additional liquid may need to be added if the bread is not combining.• If dough is too wet, add flour (by the Tbsp.) until dough becomes right consistency.• DO NOT use high speed to knead dough.
Batter is too firm and some ingredients cling on sides of bowl	<ul style="list-style-type: none">• Use a spatula to scrape any food mixture down the sides of the mixing bowl. Add more liquid to your batter, if needed.
Mixture is curdling after the eggs have been added	<ul style="list-style-type: none">• Add eggs one at a time, beating well after each addition.• Make sure eggs are at room temperature.
Sugar crystals still visible after creaming	<ul style="list-style-type: none">• Continue to cream until sugar has dissolved, or use powdered sugar.
Lumps in batter or dough	<ul style="list-style-type: none">• Sift flours and sugar before mixing.

CLEANING & CARE

1. Turn off and unplug the mixer.
2. Always allow the appliance to cool completely before cleaning.
3. Disassemble bowl, attachment and splash guard.
4. Do not use abrasive brushes or pads, or harsh cleaning solutions.
5. Use a soft cloth, sponge or rubber spatula to remove any stuck-on food or residue. Hand wash the bowl, attachments and the splash guard in warm soapy water with a soft cloth. Rinse and dry thoroughly. The bowl and splash guard are also dishwasher safe. **DO NOT wash attachments in a dishwasher, as they may become misshapen or discolored.**
6. Wipe the exterior of the mixer with a damp cloth.
7. Do not immerse any electrical appliance, its cord, or its plug, into water.
8. Ensure all parts are dried thoroughly before reassembling and using this appliance.

Fluffy Pancakes

1½ cups flour	2 eggs
2 tsp. baking powder	3 Tbsp. butter, melted
1 tsp. sugar	1¼ cups low fat milk
½ tsp. salt	

1. Combine flour, baking powder, sugar and salt in mixer bowl. Blend.
2. Add remaining ingredients. Attach bowl and beater to mixer and mix until all combined on medium speed (about 30 seconds). Scrape bowl and mix on medium speed until smooth (about 15 seconds).
3. Spray griddle or skillet with cooking spray (or wipe with oil and a paper towel). Heat to medium/high heat. Pour about ⅓ cup of batter for each pancake onto griddle.
4. Cook 1–2 minutes, or until bubbles form on surface of pancake and edges start to brown. Flip and cook another 1–2 minutes until golden brown on underside.

Serves 4

RECIPES

Curry Chicken Salad

- 8 oz. cooked chicken, cut into chunks (1 skinless, boneless breast)
- 1 stalk celery, cut into pieces
- ½ med onion
- ⅓ cup mayonnaise
- ¼ cup cilantro leaves
- 3 tsp. lemon juice
- 2 tsp. curry powder
- salt & pepper to taste

1. Place chicken in mixer bowl. Using beater (and splash guard) shred the chicken on medium speed.
2. Add all remaining ingredients and mix on low until blended.

Serves 2–4

Crowd-Pleasing Guacamole

- 2 avocados
- ¼ large onion, chopped
- 2–3 cloves garlic, minced
- 2 Tbsp. canned jalapeno slices,
chopped
- 2 Tbsp. lemon juice
- ½ tsp. salt
- 2 Tbsp. chunky salsa (optional)

1. Mash the avocados using beater on speed 2–3.
2. Add remaining ingredients and mix on low until desired consistency is reached, scraping sides of bowl with a spatula as needed.

Serves 4

RECIPES

Garlic, Chives and Dill Slow Cooker Bread

1¼ cups very warm water	3 Tbsp. olive oil
1 Tbsp. yeast	2 tsp. garlic, minced
1 tsp. sugar	2 Tbsp. dill weed
3 cups flour	¼ cup chives, chopped
1 tsp. salt	

1. Line your slow cooker pot with parchment paper (press it in as well as you can - it won't be perfectly smooth). Preheat the slow cooker on LOW.
2. Mix the water, yeast and sugar in a small bowl and set aside for a while as it foams.
3. In your mixer bowl, stir together the remaining ingredients. Attach the bowl to the mixer, and on low speed, add in the yeast mixture.
4. Using your mixer with dough hooks, knead the bread dough for about 5–7 minutes. Stop and scrape as needed. If mixtures seems too wet, sprinkle in a little more flour; if the mixture seems too dry, sprinkle in a little water.
5. Dough is ready when it forms a ball and the surface bounces back when poked.
6. Put the ball of dough in the slow cooker pot on the parchment paper. Layer a couple paper towels under the lid (to catch condensation) and cook on HIGH for 2 hours. Carefully remove the lid and paper towels for the last 15 minutes of cooking.
7. Please note: the top of the loaf will not be browned like the bottom. Remove the bread from the pot by lifting on the parchment paper. Cool before slicing.

Makes 1 loaf

RECIPES

Bacon Horseradish Mashed Potatoes

10 medium potatoes	8 strips bacon, cooked and chopped
½ tsp. salt	¼ cup sour cream
2 Tbsp. butter	4 tsp. horseradish
½ cup broth or milk	salt & pepper, to taste

1. Peel potatoes (or scrub well and do not peel), and cut into large chunks. Add the potatoes to a large pot, cover with water, and bring to a boil. Add salt and boil until tender (about 15 minutes).
2. Drain the potatoes and put them in the mixer bowl. Mash the potatoes with beater on 2–3.
3. Add remaining ingredients and mix until creamy.

Serves 4–6

Apple Cake (submitted by Lucy G. 9-10-15)

butter	2 Tbsp. sugar
2 apples	1 tsp. cinnamon
½ cup water	white cake mix

1. Preheat the oven according to cake mix box instructions.
2. Rub the cake pan with butter.
3. Peel and core the apples. Slice into wedges ¼" thick. Place apple wedges on bottom of the buttered pan.
4. Pour the water over the apples. Sprinkle the apples with the sugar and cinnamon.
5. Prepare the cake mix according to box instructions and pour the batter over the apples.
6. Bake until the top of the cake is golden brown (25 minutes was perfect for two 9" cake pans at 350°F). Serve with whipped cream or ice cream.

Serves 16

Pumpkin Applesauce Bars with Cream Cheese Frosting

4 eggs	2 tsp. cinnamon
1½ cups applesauce	8 oz. low fat cream cheese, softened
1 can (15 oz.) pumpkin pie mix	¼ cup butter, melted
2 cups flour	1¾ cup powdered sugar
2 tsp. baking powder	1 tsp. vanilla extract
1 tsp. salt	1–2 Tbsp. milk

1. Preheat oven to 350°F.
2. Beat the eggs, applesauce and pie mix on low/medium, until blended.
3. Continue mixing while slowly adding the flour. Add the baking powder, salt and cinnamon. Stop and scrape the bowl as needed.
4. Spray an oven-safe pan with cooking spray (use a 15" x 10" or 16" x 11" pan so you have thin bars). Pour in the batter and bake for 20–25 minutes, until done in the middle.
5. To make the frosting, beat the cream cheese, butter, sugar and vanilla together. Slowly add the milk until desired consistency is reached.
6. Ensure bars are completely cooled before adding frosting.

Makes 24 bars

Cinnamon Macaroons

14 oz. sweetened shredded coconut	¼ tsp. salt
14 oz. sweetened condensed milk	2 egg whites
½ tsp. vanilla extract	cinnamon

1. Preheat the oven to 325° F.
2. In a large bowl, combine the coconut, milk, vanilla and salt.
3. In a mixing bowl, with your mixer on med-high speed, whip the egg whites to firm peaks.
4. Fold the egg whites into the coconut mixture and stir to combine well.
5. Drop the mixture by heaping teaspoon onto parchment-lined cookie sheets (these cookies will really stick to your pan if you don't use the parchment).
6. Sprinkle each cookie with a little cinnamon, and bake for 20 minutes, or until the tops are browning.

Makes 2–3 dozen cookies

WARRANTY

Ginny's warrants this product free from defects in material and workmanship for one year from provable date of purchase.

Within this warranty period, Ginny's will repair or replace, at its option, defective parts at no charge, provided the product is returned, freight prepaid with proof of purchase to Ginny's. Allow 2-4 weeks for return shipping.

This warranty does not cover improper installation, misuse, abuse or neglect on part of the owner. Warranty is also invalid in any case that the product is taken apart or serviced by an unauthorized service station.

This warranty gives you specific legal rights and they may vary from state to state.

THE FOREGOING WARRANTIES ARE IN LIEU OF ALL OTHER WARRANTIES AND CONDITIONS, EXPRESS OR IMPLIED, INCLUDING BUT NOT LIMITED TO THOSE OF MERCHANTABILITY OR FITNESS FOR A PARTICULAR PURPOSE.



Ginny's, Inc.
1112 7th Avenue
Monroe, WI 53566

Customer Service: 800-544-1590
8:00 a.m. to Midnight CST, Monday through Friday