

Montgomery  
Ward®

Montgomery®  
Ward

Keep  
your  
cool!

## 5.0 Cu. Ft. Chest Freezer



## Instruction Manual

Item: 762903

Montgomery Ward Customer Service  
3650 Milwaukee Street, Madison, WI 53714  
8:00 am to Midnight, Monday through Friday

**Wards.com 1•888•557•3848**

**Wards.com 1•888•557•3848**

# Montgomery Ward

Thank you for your purchase!

Thank you for purchasing your Montgomery Ward 5.0 Cu. Ft. Chest Freezer. Put through the paces by the experts, we guarantee that it will perform to the highest standard, time after time, with all the convenience, easy clean-up and durability you rely on from Wards.

## Table of Contents

Important Safeguards .....	3-4
Electrical Safety .....	4
Specifications .....	4
Parts & Features.....	5
How to Use .....	6
Cleaning & Care.....	7-8
Troubleshooting .....	9
Notes .....	10-11
Return Information .....	12
Warranty.....	13



### READ CAREFULLY BEFORE USING AND SAVE THESE INSTRUCTIONS!

- FOR HOUSEHOLD USE ONLY. DO NOT use this appliance for other than its intended use.
- REMOVE all packaging materials and labels before first use. Please dispose of the packaging materials via the appropriate recycling system, in an environmentally friendly manner.
- Wipe inside or refrigerator with a damp cloth.
- A SHORT CORD is provided to reduce the hazards resulting from entanglement or tripping. DO NOT drape the cord where it can be pulled on or tripped over. Never wrap the cord tightly around the appliance, as this could cause the cord to fray or break.
- **We DO NOT recommend using an extension cord with this appliance.** However, IF AN EXTENSION CORD IS USED, the marked electrical rating should be at least as great as the electrical rating of this appliance.
- CLOSE SUPERVISION is necessary when using this refrigerator near CHILDREN. DO NOT allow children to climb or stand on this freezer.
- Keep fingers out of the clearances between the freezer lid and cabinet. Be careful closing when children are in the area.
- A fire may occur if this appliance is used near FLAMMABLE MATERIALS, including curtains, towels, walls, etc. DO NOT place any paper, plastic, or other non-food items in the appliance. DO NOT place the appliance or its cord on or near a heated surface, or in a heated oven.
- This appliance should always be used on a STABLE, DRY, HEAT-RESISTANT SURFACE. DO NOT use near water. This freezer was not designed to operate in temperatures below 55° Fahrenheit.
- DO NOT use an accessory or attachment not recommended by Wards, as this may cause injury, or damage the appliance.
- Do not use outdoors.
- Turn OFF AND UNPLUG this appliance when not in use. Turning the temperature control dial to "0" stops cooling but DOES NOT shut off power to the freezer.
- NO SERVICEABLE PARTS INSIDE THIS APPLIANCE.
- DO NOT USE AN APPLIANCE WITH A DAMAGED CORD OR PLUG, OR AFTER THE APPLIANCE MALFUNCTIONS, OR HAS BEEN DAMAGED IN ANY MANNER.
- Appliances/tools contain valuable materials that can be recycled. Please dispose of your old appliances/tools using appropriate collection systems.
- **RISK OF CHILD ENTRAPMENT! Before you throw away a freezer, take off doors or lids to reduce risk of danger to children.**

## Important Safeguards (cont'd)

- Do not refreeze foods which have been thawed completely. The United States Department of Agriculture in Home and Garden Bulletin No. 69 reads: "...You may safely refreeze frozen foods that have thawed if they still contain ice crystals or if they are still cold-below 40°F". "...Even partial thawing and re-freezing reduce the eating quality of foods, particularly fruits, vegetables, and prepared foods. The eating quality of red meats is affected less than that of many other foods. ...Thawed ground meats, poultry, or fish that have any off-odor or off-color should not be refrozen and should not be eaten. Thawed ice cream should be discarded. If the odor or color of any food is poor or questionable, discard it. The food may be dangerous to eat."
- **This freezer should not be recessed or built-in an enclosed cabinet. It is designed for freestanding installation only.**
- Do not operate your freezer in the presence of explosive fumes.

## Electrical Safety

**This appliance is equipped with a 3-prong grounding plug.** This is a safety feature to reduce the risk of electrical shock. Using an extension cord is not recommended with this appliance. It is recommended that an electrical outlet serving ONLY this appliance be used. This outlet must be properly installed and grounded. If you have any questions about the grounding or electrical instructions, contact a qualified electrician. Do not attempt to modify the plug in any way. Montgomery Ward cannot accept any liability for damage or injury resulting from failure to observe these safety procedures.

## Specifications

<b>POWER RATING</b>	<b>120V, 60Hz, 1.1A</b>
<b>CAPACITY</b>	<b>5.0 cubic feet</b>
<b>CORD LENGTH</b>	<b>60"</b>
<b>DIMENSIONS</b>	<b>22" W x 32" H x 29" L</b>
<b>MODEL</b>	<b>FRF451</b>

## Parts & Features

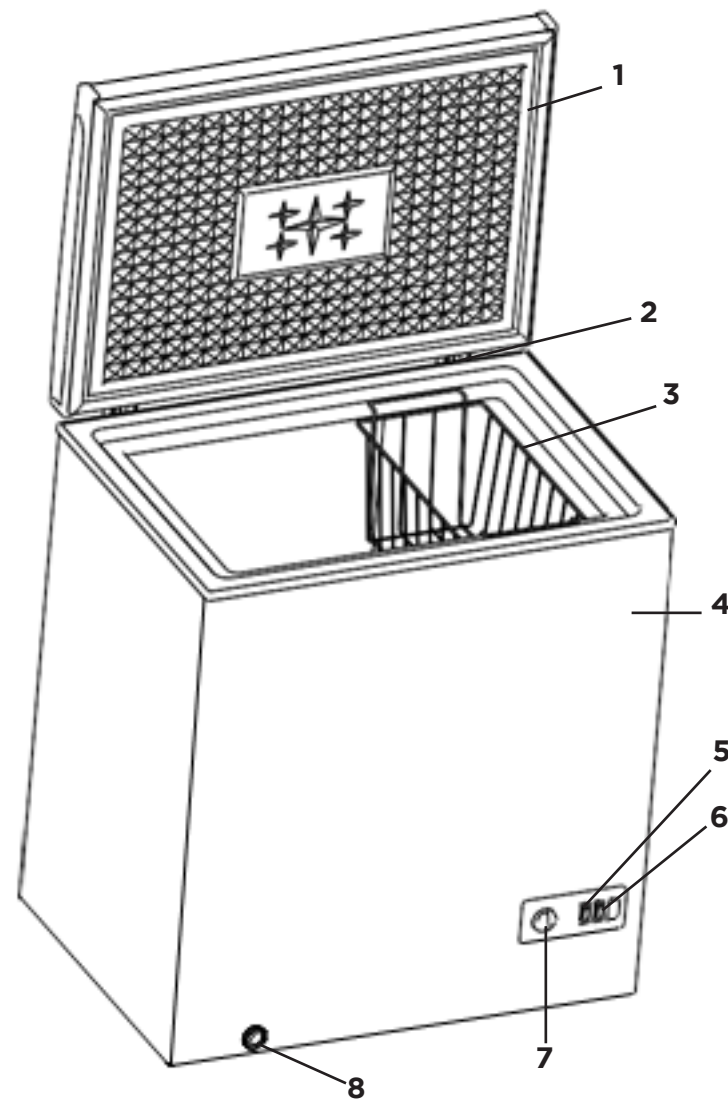

1. Lid
2. Hinges (2)
3. Basket
4. Cabinet
5. Power On Indicator (red)
6. Compressor On Indicator (green)
7. Temperature Control Knob
8. Exterior Drain Plug

**NOTE:** If the freezer has been placed in a horizontal or tilted position for any period of time, wait 24 hours before plugging the unit in. When moving the freezer, never tilt it more than a 45-degree angle. This could damage the compressor.

1. Place the freezer on an even floor, strong enough to support the freezer fully loaded.
2. To assure your freezer works at the maximum efficiency, install it where there is at least 4" of clearance on all sides. There should be enough room above the freezer so the lid can open and extend completely.
3. Keep away from direct sunlight or heat sources (radiators, baseboard heaters or cooking appliances).
4. The first time you turn the unit on, turn the temperature control dial to "ON" and run for at least 2 hours, then turn dial to "4". Check after 24 hours to ensure you have the setting cold enough ("1" being the warmest and "7" being the coldest).
5. During operation, the freezer may make certain sounds, which are normal:
  - Gurgling sounds or slight vibrations are the result of the refrigerant circulating through the cooling coils.
  - The thermostat control will click when it cycles on and off.

**WARNING:** After your freezer is in operation, do not touch the cold surfaces in the freezer compartment, particularly when hands are damp or wet. Skin may adhere to these cold surfaces.

### Defrosting and Draining

**For most efficient operation and minimum energy consumption, defrost the freezer whenever the frost becomes  $\frac{1}{4}$ " thick.**

1. We recommend letting ice and frost melt naturally.
  - NEVER use sharp or metallic instruments to remove the frost, as it may damage the cooling coils. (A punctured coil will void the warranty).
  - DO NOT use boiling water, as it may damage the unit.
2. Remove frozen food from the freezer and place it in a cooler to keep it frozen.
3. Turn off and unplug the unit.
4. Defrosting usually takes a few hours. To defrost faster, keep the freezer door open.
5. For draining, place a container beneath the exterior drain plug. Open the interior and exterior drain plugs to let the water flow out into the container.

**Note: monitor the container under the drain to avoid overflow.**

6. When done draining, close both the interior and exterior drain plugs.
7. Wipe the interior of the freezer with a soft cloth.
8. Plug in the power cord and reset the temperature control to the desired setting.
9. Return the food to the freezer.

## Cleaning

**WARNING: To avoid electrical shock, always unplug your freezer before cleaning. Ignoring this warning may result in death or injury.**

**Caution: Before using cleaning products, always read and follow manufacturer's instructions and warnings to avoid personal injury or product damage.**

1. Prepare a cleaning solution of 3-4 tablespoons of baking soda mixed with warm water. Use a sponge or soft cloth, dampened with the cleaning solution, to wipe down the interior of the freezer.
2. Rinse with clean warm water and dry with a soft cloth.
3. Do not use harsh chemicals, abrasives, ammonia, chlorine bleach, solvents or metal scouring pads. Some of these chemicals may dissolve, damage and/or discolor the freezer interior.
4. Clean door gaskets every three months. Gaskets must be kept clean and pliable to assure a proper seal. Petroleum jelly (applied lightly on the hinge side of gaskets) will keep the gaskets in proper condition.
5. **Do not immerse any electrical appliance, its cord, or its plug, into water.**

## Power Interruptions

Occasionally there may be power interruptions due to thunderstorms or other causes.

1. Unplug the freezer when a power outage occurs.
2. When power has been restored, plug the unit back in.
3. If an outage lasts for a prolonged period, inspect and discard spoiled or thawed food from the freezer.

## Vacation Care

1. For long vacations or absences, empty food from freezer and unplug the unit.
2. Clean the door gaskets.
3. Prop the door open, so air can circulate inside the freezer.

## Freezer Does Not Operate:

- Check if freezer is plugged in.
- Check if there is power at the outlet, by checking the circuit breaker.
- Wait for 30-40 minutes to see whether freezer will start. Compressor cycle must be complete to operate.

## Food temperature appears too warm:

- Frequent door openings.
- Allow time for recently added warm food to reach freezer temperature.
- Check gaskets for proper seal.
- Adjust temperature control to colder setting.

## Too much frost build-up inside unit:

- Make sure temperature control is not set to "ON" setting for extended period of time.

## Food temperature is too cold:

- If temperature control setting is too cold, adjust to a warmer setting and allow several hours for temperature to adjust.

## Compressor runs too frequently:

- This may be normal to maintain constant temperature during high temperature and humid days.
- Doors may have been opened frequently or for an extended period of time.
- Check gasket for proper seal.
- Check to see if doors are completely closed.
- Check freezer compartment for blockage from frozen food packages, containers, etc.

## Freezer has an odor:

- Interior needs cleaning.
- Foods improperly wrapped or sealed are giving off odors.



If any item, for any reason, does not meet your expectations, just return it to us. We'll gladly either:

- Refund your merchandise amount
- Credit your account
- Send a replacement

You can return any unused item in its original packaging within 60 days of its receipt for a full refund of the purchase price (excluding shipping and handling charges).

**Please send returns to:**

**Montgomery Ward, Inc.  
Attn: Customer Returns  
2000 Harrison Suite 100  
Clinton, IA 52732-6676**

**When returning an item:**

- Use the original packaging and pack it securely.
- Please adequately insure your item in case you need to make a claim with the carrier you choose for returning your item.
- Include your order number and reason for return.
- We recommend keeping the receipt for 4 weeks.

# Montgomery<sup>®</sup> Ward

## 1 Year Limited Warranty

Montgomery Ward, Inc. warrants this product to be free from defects in material and workmanship for one year from provable date of purchase.

Within this warranty period, Montgomery Ward will repair or replace, at its option, defective parts of this product at no charge, provided the product is returned, freight prepaid with proof of purchase to Montgomery Ward.

Allow 2-4 weeks for return shipping.

This warranty does not cover improper installation, misuse, abuse or neglect on part of the owner. Warranty is also invalid in any case that the product is taken apart or serviced by an unauthorized service station.

This warranty gives you specific legal rights and they may vary from state to state.

THE FOREGOING WARRANTIES ARE IN LIEU OF ALL OTHER WARRANTIES AND CONDITIONS, EXPRESS OR IMPLIED, INCLUDING BUT NOT LIMITED TO THOSE OF MERCHANTABILITY OR FITNESS FOR A PARTICULAR PURPOSE.

Montgomery Ward Customer Service  
8:00 am to Midnight CST, Monday through Friday

**Wards.com 1-888-557-3848**

