

**Montgomery  
Ward**

**Montgomery  
Ward**

*This  
oven does  
it all!*

## 1.2 Cu. Ft. 3-in-1 Microwave Oven



## Instruction Manual

Montgomery Ward Customer Service  
8:00 am to Midnight, Monday through Friday

Item: 788912

**wards.com 1•888•557•3848**

**wards.com 1•888•557•3848**

# Montgomery Ward

Thank you for your purchase!

Thank you for purchasing your Montgomery Ward 1.2 cu. ft. 3-in-1 Microwave Oven. Put through the paces by the experts, we guarantee that it will perform to the highest standard, time after time, with all the convenience, easy cleanup and durability you rely on from Wards.

## Table of Contents

Important Safeguards .....	3-4
Electrical Safety .....	4
Specifications .....	4
Parts & Features.....	5-6
How to Use .....	7-13
Cleaning & Care.....	14
Troubleshooting .....	15
Recipes.....	16-19
Return Information.....	20
Warranty.....	21



### READ CAREFULLY BEFORE USING AND SAVE THESE INSTRUCTIONS!

- FOR HOUSEHOLD USE ONLY. DO NOT USE THIS APPLIANCE FOR OTHER THAN ITS INTENDED USE.
- Remove all packaging materials before first use. Remove any protective film found on the microwave oven cabinet surface.
- **DO NOT remove the wave guide/mica plate inside the oven cavity!**
- **Wash all removable parts and wipe down the inside of the oven before first use. See Cleaning & Care.**
- Wipe up spills with a damp cloth as they occur.
- A short cord is provided to reduce the hazards resulting from entanglement or tripping. DO NOT drape the cord over a counter or tabletop where it can be pulled on or tripped over.
- We DO NOT recommend using an extension cord with this appliance. However, if an extension cord is used, the marked electrical rating should be at least as great as the electrical rating of this appliance.
- CLOSE SUPERVISION IS NECESSARY WHEN USING THIS APPLIANCE NEAR CHILDREN.
- A fire may occur if this appliance is used near flammable materials. DO NOT overcook food. Carefully attend when paper, plastic or other combustible materials are being used for cooking.
- IF MATERIALS INSIDE THE OVEN SHOULD IGNITE, KEEP OVEN DOOR CLOSED, TURN OVEN OFF AND DISCONNECT THE POWER CORD OR SHUT OFF POWER AT THE CIRCUIT BREAKER PANEL.
- DO NOT place the oven or its cord on or near a heated surface.
- Use this appliance on a stable, dry, heat-resistant surface.
- DO NOT use this product near water.
- DO NOT use an accessory or attachment not recommended by Wards, as this may cause injury, or damage the appliance.
- Keep hands, hair and clothing away from all moving parts.
- Always use oven mitts when handling hot food or appliances.
- DO NOT ATTEMPT TO OPERATE THIS OVEN WITH THE DOOR OPEN. Open-door operation can result in harmful exposure to microwave energy. DO NOT TAMPER WITH THE DOOR SAFETY LOCKS. DO NOT ALLOW FOOD OR CLEANER RESIDUE TO BUILD UP AROUND DOOR AREA.
- Products such as whole eggs in the shell and sealed containers should not be heated in this oven, as they may explode.
- Liquids can be overheated beyond the boiling point without appearing to be boiling due to surface tension of the liquid. Visible bubbling or boiling when the container is removed from the oven is not always present. THIS COULD RESULT IN VERY HOT LIQUIDS SUDDENLY BOILING OVER WHEN A SPOON OR OTHER UTENSIL IS INSERTED INTO THE LIQUID.
- DO NOT heat oil or fat in large quantities (like for deep frying) in this oven.
- The contents of baby bottles and jars should be stirred or shaken and the temperature should be checked before serving in order to avoid burns.

(continued on next page)

## Important Safeguards

- Pierce foods with heavy skins, such as whole potatoes or whole squash, before cooking, as they may explode.
- DO NOT cover or block any openings on the appliance. Allow 4" for the back, 8" above and 3" on the sides between the oven and wall or cabinet.
- This oven generates, uses, and can radiate radio frequency energy and may cause interference to your TV or radio. Try to correct interference by increasing the separation between the equipment and the oven. Consult an experienced radio/TV technician for help.
- DO NOT use outdoors.
- THERE ARE NO SERVICEABLE PARTS INSIDE THIS APPLIANCE.
- DO NOT USE AN APPLIANCE WITH A DAMAGED CORD OR PLUG, OR AFTER THE APPLIANCE MALFUNCTIONS OR HAS BEEN DAMAGED IN ANY MANNER.
- Appliances/tools contain valuable materials that can be recycled. Dispose of your old appliances/tools using appropriate collection systems in accordance with federal and local regulations.

## Electrical Safety

**This appliance is equipped with a 3-prong grounding plug.** This is a safety feature to reduce the risk of electrical shock. Using an extension cord is not recommended with this appliance. It is recommended that an electrical outlet serving ONLY this appliance be used. This outlet must be properly installed and grounded. If you have any questions about the grounding or electrical instructions, contact a qualified electrician. DO NOT attempt to modify the plug in any way. Montgomery Ward cannot accept any liability for damage or injury resulting from failure to observe these safety procedures.

## Specifications

OUTPUT REQUIREMENTS	120V/60 Hz/1000W
POWER RATING INPUT	120V/60 Hz/1500W (MWO), 1450W (Convection)
CAPACITY	1.2 CU FT
CORD LENGTH	40"
OUTSIDE DIMENSIONS	21¼" W x 11¼" H x 20" D +/- ½"
NET WEIGHT	APPROXIMATELY 41 LBS.
MODEL	MW1205-MW

## Parts & Features

(Diagram may vary slightly from actual item.)

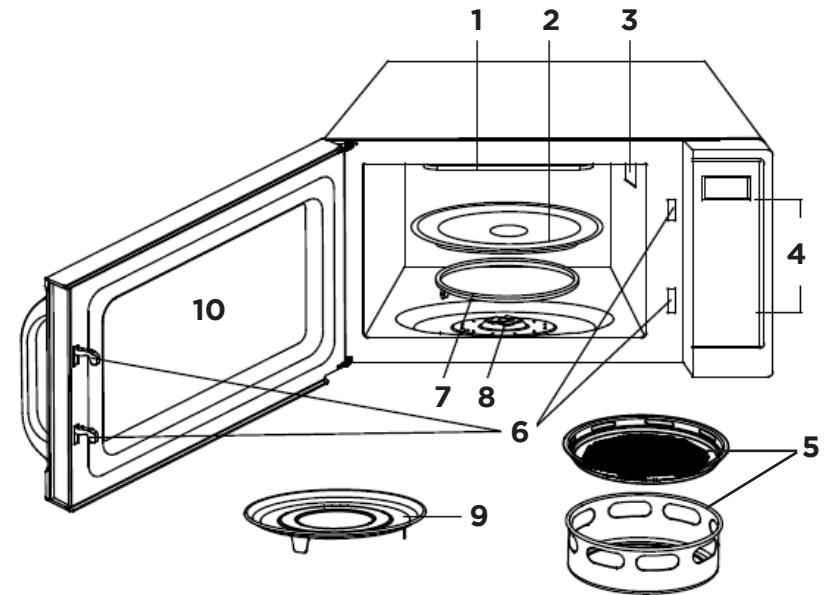

1. Heating Element
2. Glass Turntable
3. Wave Guide/Mica Plate
4. Control Panel (detail on page 6)
5. Air Fry Plate and Riser
6. Door Locking System
7. Roller Ring
8. Shaft
9. Bake Pan/Drip Pan
10. Door with Window

**Control Panel**



**SETTING THE CLOCK**

1. Press and hold CLOCK/TIMER for 3 seconds to choose 24-hour clock, then press it again to choose 12-hour clock.
2. Press numbers to enter time.
3. Press CLOCK/TIMER to finish.

**TIMER**

1. Press CLOCK/TIMER once.
2. Press numbers to enter desired time. The longest time is 99 minutes and 99 seconds.
3. Press START.
4. When the timer countdown ends, the oven will beep.
5. Press STOP/CANCEL to cancel the timer.

**MICROWAVE COOKING**

1. Press MICRO to select desired power:

Press MICRO	Power Level	Display
Once	100%	P-HI
Twice	90%	P-90
3 times	80%	P-80
4 times	70%	P-70
5 times	60%	P-60
6 times	50%	P-50
7 times	40%	P-40
8 times	30%	P-30
9 times	20%	P-20
10 times	10%	P-10

2. Press numbers to enter desired cooking time. The longest cooking time is 99 minutes and 99 seconds.
3. Place the food inside the oven. Press START.
4. Press STOP/CANCEL to cancel cooking.

**MULTI-STAGE MICROWAVE COOKING**

1. Place food into the oven.
2. Input the first microwave cooking program (instructions above). DO NOT press START.
3. Input the second microwave cooking program.
4. Press START.

**PRESET BUTTONS FOR MICROWAVE AUTO COOK**

1. Press 1 of the following menu buttons repeatedly to select food weight:
  - a. POPCORN (1.75–3.5 oz.)
  - b. POTATO (8–24 oz.)
  - c. BEVERAGE (8–12 oz.)
  - d. REHEAT (8–24 oz.)
  - e. FROZEN DINNER (8–24 oz.)
2. Place the food inside the oven. Press START.
3. Press STOP/CANCEL to cancel cooking.

**TIME DEFROST**

1. Press DEFROST/TIME/WEIGHT.
2. Press numbers to enter time. The longest defrosting time is 99 minutes and 99 seconds.
3. Place the food inside the oven. Press START.
4. Press STOP/CANCEL to cancel defrosting.

**WEIGHT DEFROST**

1. Press DEFROST/TIME/WEIGHT twice.
2. Press number 1 (meat, maximum 48 oz.), 2 (poultry, maximum 48 oz.) or 3 (seafood, maximum 32 oz.) to select food category.
3. Place the food inside the oven. Press START.
4. Press numbers to enter food weight.
5. Press START.
6. Press STOP/CANCEL to cancel defrosting.

**Note:** During the defrosting process, the oven will beep and pause to remind you to turn over the food. Press START to resume defrosting.

**+30 SEC FUNCTION**

Press +30 SEC to automatically start the microwave oven cooking at 100% in 30-second increments.

**CONVECTION COOKING**

1. Press CONV.
2. Press numbers to enter the desired temperature (1=180° F, 2=225° F, 3=250° F, 4=275° F, 5=300° F, 6=325° F, 7=335° F, 8=350° F, 9=375° F and 0= 400° F).
3. Press START. The oven will beep when the designated temperature is reached. The longest preheat time is 30 minutes.
4. Place the food inside the oven on top of the bake pan.
5. Press numbers to enter cooking time. The longest time is 99 minutes and 99 seconds.
6. Press START.
7. Press STOP/CANCEL to cancel cooking.

**MICROWAVE+CONVECTION COOKING**

1. Press MICRO+CONV 1–4 times to select temperature (225° F, 275° F, 350° F or 400° F).
2. Place the food inside the oven.
3. Press numbers to enter cooking time. The longest time is 99 minutes and 99 seconds.
4. Press START.
5. Press STOP/CANCEL to cancel cooking.

**Note:** When the bake, air fry or roast functions are first used, the oven may produce slight smoke and smell. This is normal and will dissipate with use.

## BAKING

1. Press BAKE.
2. Press numbers to set the temperature (1=180° F, 2=225° F, 3=250° F, 4=275° F, 5=300° F, 6=325° F, 7=335° F, 8=350° F, 9=375° F and 0= 400° F).
3. Press START.
4. Press numbers to enter the cooking time. The longest time is 99 minutes and 99 seconds.
5. Press START. The oven will beep when the designated temperature is reached.
6. Place the food in the oven in an oven-safe pan on top of the bake pan.
7. Press START.
8. To use BAKE *presets*, press BAKE twice, then press BAKE 1-3 times to select a food code:
  - Ab-1 Cookies 350° F 10 mins.
  - Ab-2 Brownies 350° F 45 mins.
  - Ab-3 Cake 350° F 23 mins.
9. Press START. The oven will beep when the designated temperature is reached.
10. Place the food in the oven in an oven-safe pan on top of the bake pan.
11. Press START.
12. Press STOP/CANCEL to cancel cooking.

## AIR FRYING

1. Press AIR FRY.
2. Press numbers to set the temperature (1=180° F, 2=225° F, 3=250° F, 4=275° F, 5=300° F, 6=325° F, 7=335° F, 8=350° F, 9=375° F and 0= 400° F).
3. Press START.
4. Press numbers to enter the cooking time. The longest time is 99 minutes and 99 seconds.
5. Place the food in the oven on the air fry plate on top of the riser and the drip pan and press START.
6. To use AIR FRY *presets*, press AIR FRY twice, then press AIR FRY 1-7 times to select a food code (see table on next page).
7. Press START.
8. Press AIR FRY repeatedly to set the food weight.
9. Place the food in the oven on the air fry plate on top of the riser and the drip pan and press START.
10. Press STOP/CANCEL to cancel cooking.

AIR FRY Preset	Food	Weight (oz.)	Minutes	Temperature
AF-1	Onion Rings	8	23	400° F
AF-2	Chicken Drumsticks	8	36	400° F
		12	39	
		16	42	
		20	45	
		24	48t	
AF-3	Chicken Wings	8	36	400° F
		12	38	
		16	40	
		20	42	
AF-4	Chicken Nuggets	6	24	400° F
		8	26	
		10	28	
		12	30	
AF-5	Popcorn Chicken	8	26	400° F
		10	28	
		12	30	
		16	32	
AF-6	Mozzarella Sticks	6	14	400° F
		8	15	
		12	16	
		14	17	
		16	18	
AF-7	Frozen French Fries	10	33	400° F

## ROASTING

1. Press ROAST.
2. Press numbers to set the temperature (1=180° F, 2=225° F, 3=250° F, 4=275° F, 5=300° F, 6=325° F, 7=335° F, 8=350° F, 9=375° F and 0= 400° F).
3. Press START.
4. Press numbers to enter the cooking time. The longest time is 99 minutes and 99 seconds.
5. Place the food in the oven on top of the bake pan. Press START.
6. To use ROAST *presets*, press ROAST pad twice, then press ROAST 1-5 times to select a food code (see table below).
7. Press START.
8. Press ROAST repeatedly to set the food weight (see table below).
9. Place the food in the oven on top of the bake pan and press START.
10. Press STOP/CANCEL to cancel cooking.

ROAST Preset	Food	Weight	Minutes
Ar-1	Salmon Filet	4 oz.	25
		8 oz.	28
		12 oz.	31
		16 oz.	34
		20 oz.	37
Ar-2	Whole Chicken	4 lbs.	60
Ar-3	Pork Loin	2 lbs.	35
		3 lbs.	45
Ar-4	Pork Tenderloin	1 lb.	25
		2 lbs.	35
Ar-5	Roasted Potatoes	4 oz.	32
		6 oz.	34
		8 oz.	36
		10 oz.	38
		12 oz.	40
		16 oz.	42

## CHILD LOCK

1. To prevent unsupervised operation of the oven, set the child lock by pressing and holding STOP/CANCEL for 5 seconds. A beep will sound and a LOCK indicator will show in the display window.
2. To cancel, press and hold STOP/CANCEL for 5 seconds until lock indicator on display turns off.

## ERROR CODES

1. EO3: When the system enters into super high temperature protection status, the display shows "EO3" and continues to beep. Press STOP/CANCEL and the system will come back to normal standby mode.
2. EO4: When the system enters into super low temperature protection status, the display shows "EO4" and continues to beep. Press STOP/CANCEL and the system will come back to normal standby mode.
3. EO5 or EO6: When the system sensor is open circuited or short circuited, the display shows "EO5" or "EO6" and the buzzer makes an alarm sound. Press STOP/CANCEL and the system will come back to normal standby mode.
4. FAIL: If any pad on the control panel is depressed for 60 seconds, the program stops, the display shows "FAIL" and the system will beep every minute. Press STOP/CANCEL and the system will come back to normal standby mode.

**Failure to maintain the oven in a clean condition could lead to deterioration of the surfaces, which could shorten the life of this oven and possibly result in a hazardous situation.**

1. Turn off the oven and remove the power plug from the outlet before cleaning.
2. When food splatters or spilled liquids adhere to oven walls, wipe them with a damp cloth. Mild detergent may be used if the oven gets very dirty. Avoid the use of spray and other harsh cleaners as they may stain, streak or dull surfaces.
3. The outside surfaces should be cleaned with a damp cloth. DO NOT let water seep into any vent openings.
4. Wipe the door and window on both sides, as well as the door seals and adjacent parts, frequently with a damp cloth to remove any spills or splatters.
5. DO NOT allow the control panel to become wet. Clean with a soft, damp cloth. When cleaning the control panel, leave oven door open to prevent oven from accidentally turning on.
6. If steam accumulates inside or around the outside of the oven door, wipe with a soft cloth.
7. Wash the glass turntable in warm sudsy water or in a dishwasher, as needed.
8. The air fry plate, riser and drip pan should be washed after every use in warm sudsy water.
9. The roller ring and oven floor should be cleaned regularly to avoid excessive noise. Wipe the floor of the oven with mild detergent. The roller ring may be washed in mild sudsy water or in a dishwasher. Be sure to replace the ring and turntable to correct position before operating oven.
10. Remove odors from your oven by combining a cup of water with the juice and skin of one lemon in a deep microwave-safe bowl. Heat on high power for 5 minutes. Wipe down interior thoroughly and dry with a soft cloth.

**11. DO NOT immerse any electrical appliance, cord or plug into water.**

**12. DO NOT use a steam cleaner in this oven!**

Trouble	Possible Cause	Possible Remedy
Oven will not operate	a. Electrical cord is unplugged. b. Door is open. c. Wrong operation is set.	a. Plug into the outlet. b. Close the door. c. Check instructions.
Arcing or sparking	a. Materials to be avoided in microwave oven were used. b. The oven is operated when empty. c. Spilled food remains in the interior.	a. Use microwave-safe cookware when using microwave functions. b. DO NOT operate with oven empty. c. Clean cavity with a damp cloth.
Unevenly cooked or undercooked foods	a. Materials to be avoided in microwave oven were used. b. Food is not defrosted completely. c. Cooking time or power level is not suitable. d. Food is not turned or stirred. e. Oven vents are restricted.	a. Use microwave-safe cookware when using microwave functions. b. Completely defrost food, then cook. c. Use correct cooking time, power level. d. Turn or stir food. e. Make sure ventilation is not restricted.
Overcooked foods	Cooking time or power level is not suitable.	Use correct cooking time, power level.
Improper defrosting	a. Materials to be avoided in microwave oven were used. b. Cooking time or power level is not suitable. c. Food is not turned or stirred.	a. Use microwave-safe cookware only when defrosting. b. Use correct cooking time, power level. c. Turn or stir food.

## Scrambled Eggs

3 eggs  
2 Tbsp. milk

salt & pepper, to taste

1. To avoid cross contamination, wash hands and utensils after touching raw eggs.
2. Stir all ingredients together in a microwave-safe bowl or mug.
3. Cover with a paper towel and cook on HIGH 45 seconds. Stir and cook another 45 seconds. Let sit for 30 seconds and serve.

Serves 1

## Cheddar Grits with Green Onions

1 cup uncooked instant grits	2 cloves garlic, minced
1½ cups broth or water	1½ cups cheddar cheese, grated
¼ cup butter, softened	dash cayenne pepper
3 green onions, chopped	salt & pepper, to taste

1. Mix all ingredients in a microwave-safe bowl.
2. Cover and cook at 100% power in 1-minute intervals, stirring in between, until grits are cooked (3–5 minutes total).

Serves 2–3

## Microwave Mac & Cheese for One

½ cup elbow macaroni	½ cup shredded cheddar cheese
½ cup water	2 tsp. milk

1. Combine the macaroni and water in a microwave-safe bowl. Cook on 100% for 6 minutes, stopping to stir every 2 minutes.
2. Add the shredded cheese and cook another 45 seconds. Stir in the milk until smooth and serve.

Serves 1

## Zippy Pork Ribs

½ cup brown sugar	1 tsp. black pepper
1 tsp. cayenne pepper	1 tsp. garlic powder
1 tsp. salt	2 lbs. pork ribs

1. To avoid cross contamination, wash hands, cutting boards, utensils, etc. after touching raw meat.
2. Mix the first 5 ingredients in a small bowl to make a rub.
3. Cut the pork into single-bone sections.
4. Coat the pork generously with the rub and place the pieces on the air fry pan.
5. Cook on AIR FRY for 20 minutes at 400° F.
6. Rotate the ribs with tongs and cook for another 10 minutes at 400° F or until the internal temperature reaches 145° F.
7. Serve with your favorite barbeque sauce.

Serves 2–3

## Spicy Shrimp

¼ tsp. cayenne pepper	2 tsp. olive oil
½ tsp. Old Bay® seasoning	2 Tbsp. butter, melted
12 oz. small raw shrimp, peeled and deveined	

1. To avoid cross contamination, wash hands, cutting boards, utensils, etc. after touching raw seafood.
2. In a small bowl, thoroughly mix the cayenne and Old Bay®. Set aside.
3. Place the shrimp in a large bowl and toss with the olive oil. Then, while stirring the shrimp, sprinkle over the seasoning mix and coat evenly.
4. Pour the shrimp into the air fry pan and cook on AIR FRY at 400°F for 10 minutes.
5. When shrimp is done, toss with the melted butter and serve.

Serves 2–3

## Crispy Air Fried Chicken

1¼ cup flour  
1 tsp. pepper  
1½ tsp. salt  
½ tsp. cayenne pepper  
1 cup milk  
4 chicken thighs (skin on)

1. To avoid cross contamination, wash hands, cutting boards, utensils, etc. after touching raw poultry. DO NOT rinse raw poultry.
2. In a large bowl, whisk together the dry ingredients. Pour milk into another bowl.
3. Dredge chicken pieces in the dry ingredients, then in the milk, then back into the dry ingredients. Shake off any excess.
4. Put the coated chicken pieces onto the air fry pan in 1 layer with a little space between each piece.
5. Cook on AIR FRY at 375° F for 30 minutes. Chicken is done when internal temperature is 165° F.

Serves 4

## Quick and Easy Microwave Fudge

2 packs (8 squares each) semisweet chocolate  
1 can (14 oz.) sweetened condensed milk  
2 tsp. vanilla extract  
¼ tsp. salt  
1 cup walnuts, chopped  
butter

1. Place half the chocolate and half the milk in a microwave-safe bowl. Heat at 100% for 1 minute. Stir, then heat for another minute. Repeat with second half of chocolate and milk.
2. Combine and stir chocolate mixture until completely smooth.
3. Mix in vanilla, salt and walnuts. When blended, pour into a cake pan or cookie sheet that has been lightly greased with butter.
4. Refrigerate until firm (about 2 hours), then cut and serve.

Makes 30–40 pieces

## Sautéed Mushrooms

8 oz. fresh mushrooms, sliced  
2 Tbsp. butter, melted  
1 tsp. olive oil  
1 tsp. soy sauce  
2 cloves garlic, minced

1. Put all the ingredients in a microwave-safe bowl. Gently stir to coat the mushrooms.
2. Cook the mushrooms on HIGH about 5 minutes, stirring once (add more time in 30-second increments if softer mushrooms are desired).

Serves 2–3

## Lemon Bars

**Crust:**  
1 cup flour  
3 Tbsp. powdered sugar  
6 Tbsp. butter, melted  
zest of 1 lemon

**Filling:**  
1 cup sugar  
zest of 2 lemons  
3 eggs, at room temperature  
juice from zested lemons (about ¼ cup)  
1 Tbsp. flour  
½ tsp. baking powder  
¼ tsp. salt  
powdered sugar

1. To avoid cross contamination, wash hands and utensils after touching raw eggs.
2. Spray a 9" microwave-safe pan with cooking spray.
3. In a small bowl, mix the crust ingredients with a fork. When well blended, press the crust into the bottom of the pan.
4. Cook the crust on 80% power for 3½ minutes. The crust should be firm, but if it is not, add another 30 seconds of cooking time. Set crust aside.
5. Using a mixer, beat together the first 4 ingredients for the filling on LOW speed.
6. Add the flour, baking powder and salt, and beat on MEDIUM for 2–3 minutes until smooth.
7. Pour the filling over the crust and cook in the microwave oven at 80% power for 4–5 minutes. The center should be set, not runny.
8. Cover and refrigerate for at least 4 hours. Dust with powdered sugar before serving.

Makes 8–9 bars

If any item, for any reason, does not meet your expectations, just return it to us. We'll gladly either:

- Refund your merchandise amount
- Credit your account
- Send a replacement

You can return any unused item in its original packaging within 60 days of its receipt for a full refund of the purchase price (excluding shipping and handling charges).

**Please send returns to:**

**Montgomery Ward, Inc.  
Attn: Customer Returns  
2000 Harrison Suite 100  
Clinton, IA 52732-6676**

**When returning an item:**

- Use the original packaging and pack it securely.
- Please adequately insure your item in case you need to make a claim with the carrier you choose for returning your item.
- Include your order number and reason for return.
- We recommend keeping the receipt for 4 weeks.

# Montgomery Ward<sup>®</sup>

## 1 Year Limited Warranty

Montgomery Ward, Inc. warrants this product to be free from defects in material and workmanship for one year from provable date of purchase.

Within this warranty period, Montgomery Ward will repair or replace, at its option, defective parts of this product at no charge provided the product is returned freight prepaid with proof of purchase to Montgomery Ward.

Allow 2-4 weeks for return shipping.

This warranty does not cover improper installation, misuse, abuse or neglect on part of the owner. Warranty is also invalid in any case that the product is taken apart or serviced by an unauthorized service station.

This warranty gives you specific legal rights and they may vary from state to state.

THE FOREGOING WARRANTIES ARE IN LIEU OF ALL OTHER WARRANTIES AND CONDITIONS, EXPRESS OR IMPLIED, INCLUDING BUT NOT LIMITED TO THOSE OF MERCHANTABILITY OR FITNESS FOR A PARTICULAR PURPOSE.

Montgomery Ward Customer Service  
8:00 am to Midnight CST, Monday through Friday

**wards.com 1•888•557•3848**

